



LISTING INFORMATION OF
SIPA - Structural Insulated Panels (SIPs)
SPEC ID: 32805

Structural Insulated Panel Association (SIPA)
P.O. Box 39848
Fort Lauderdale, FL 33339
United States

This report is for the exclusive use of Intertek's Client and is provided pursuant to the agreement between Intertek and its Client. Intertek's responsibility and liability are limited to the terms and conditions of the agreement. Intertek assumes no liability to any party, other than to the Client in accordance with the agreement, for any loss, expense or damage occasioned by the use of this report. Only the Client is authorized to permit copying or distribution of this report and then only in its entirety. Any use of the Intertek name or one of its marks for the sale or advertisement of the tested material, product or service must first be approved in writing by Intertek. The observations and test results in this report are relevant only to the sample tested. This report by itself does not imply that the material, product, or service is or has ever been under an Intertek certification program.

LISTING INFORMATION

Structural Insulated Panels are factory-assembled, engineered-wood-faced, structural insulated panels (SIPs) with an expanded polystyrene (EPS) foam core. The panels are intended for use as load-bearing or non-load bearing wall and roof panels. The panels are custom made to the specifications for each use and are assembled under factory-controlled conditions.

MANUFACTURING LOCATIONS

ACME Panel Company Joe Fortier 1905 W. Main Street Radford, VA 24141 Tel: 877-331-4266 joe@acmepanel.com	Enercept, Inc. Charlie Ewalt 3100 9th Avenue SE Watertown, SD 57201 Tel: 605-882-2222 charlie@enercept.com	Energy Panel Structures, Inc. Chris Spaeth 603 N. Van Gordon Avenue Graettinger, IA 51342 Tel: 712-859-3219 cspaeth@epsbuildings.com
Foard Panel, Inc. Paul Malko 53 Stow Drive West Chesterfield, NH 03466 Tel: 603-256-8800 paul@foardpanel.com	Insulspan SIPs by Plasti-Fab Jim Whalen #1, 600 Chester Road, Annacis Business Park Delta, BC V3M 5Y3 Tel: 403-569-4312 jwhalen@plastifab.com	Insulspan SIPs by Plasti-Fab Jim Whalen 245 N Jipson Street Blissfield, MI 49228 Tel: 800-848-8855 jwhalen@plastifab.com
FischerSIPS, LLC Damian Pataluna 1844 Northwestern Parkway Louisville, KY 40203 Tel: 800-792-7477, ext. 285 damianp@fischersips.com	PorterSIPs, div. of Porter Corp Ard Smits 4240 N. 136th Avenue Holland, MI 49424 Tel: 616-836-0718 ardsmi@portercorp.com	The Murus Company, Inc. Jamie Jenkins 3234 Route 549 Mansfield, PA 16933 Tel: 800-626-8787 j_jenkins@murus.com

RATINGS

ASTM E119 / CAN/ULC S101	Fire-Resistance Rating	Design Number
6-1/2 in. SIP Wall Assembly	1-hour rating	SIP/CWP 60-02
4-1/2, 6-1/2 or 8-1/4 in. SIP Wall Assembly	1-hour rating	SIP/CWP 60-01
SIP Wood Roof/Ceiling Assembly	1-hour rating	SIP/CRP 60-01
SIP Steel Roof/Ceiling Assembly	1-hour rating	SIP/CRP 60-02

Attribute **Value**

Criteria	CAN / ULC S101 (2007)
Criteria	ASTM E119 (2012)
CSI Code	06 12 00 Structural Panels
Intertek Services	Certification
Listed or Inspected	LISTED
Listing Section	BUILDING PANELS
Spec ID	32805

DRAWING INDEX

SIP/CRP 60-01

SIP/CRP 60-02

SIP/CWP 60-01

SIP/CWP 60-02

SIP/CRP 60-01

Division 7 - Thermal and Moisture Protection
 07 40 00 Roofing and Siding Panels
 07 41 43 Composite Roof Panels

Page 1 of 2

Design Number: SIP / CRP 60-01
ROOF-CEILING SYSTEMS
Structural Insulated Panel Association (SIPA)
SIPA 4½ to 10½ in. Structural Insulated Panels
ASTM E 119 – 2012 Edition
CAN/ULC S 101 – 2007 Edition
Restricted Superimposed Load: See Item 1

Rating – 1 Hour

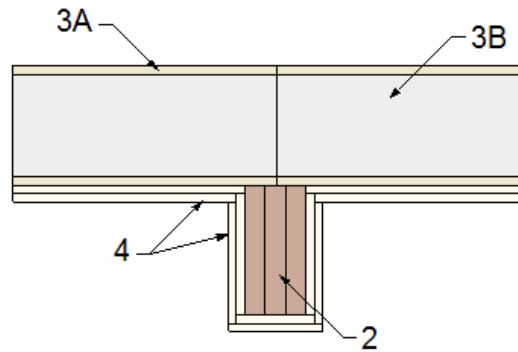

ITEM 1

- | | |
|---|---|
| <p>1. CEILING ASSEMBLY: Construct a ceiling assembly using elements described in Items 2 through 5 with a maximum restricted superimposed load of 40% of the allowable capacity of the panel.</p> <p>2. WOOD BEAMS/JOIST: Use minimum 4-1/2 in. wide x 9-1/2 in. deep engineered wood beam/joist spaced in accordance with manufacturer's design specifications and building code requirements.</p> <p>3. CERTIFIED COMPANIES: Structural Insulated Panel Association (SIPA)</p> <p>CERTIFIED PRODUCT: SIPA Structural Insulated Panels</p> <p>ROOF PANELS: Install SIPA Structural Insulated Panels consisting of the following elements:</p> | <p>A. FACING: Nominal 7/16 in. thick OSB skins factory bonded to interior and exterior sides of EPS foam core (Item 3B) conforming and identified as meeting DOC PS 2-04, Exposure 1, Rated Sheathing with a span index of 24/16 and/or CAN/CSA O325.0, Exterior Grade Sheathing with a span index of 1R24/2F16.</p> <p>B. CORE: Use ASTM C578 compliant and Listed Type I EPS (min. 0.9 pcf) with a flame spread rating not exceeding 75 and smoke-developed rating not exceeding 450 per ASTM E84 and/or CAN/ULC S701 compliant and Listed Type 1 EPS with a flame spread rating not exceeding 500 per CAN/ULC S102.2.</p> <p>C. ADHESIVE (Not Shown): Facing materials are adhered to the core material using a structural adhesive. The adhesive is applied during the</p> |
|---|---|

Date Revised: August 7, 2013
 Revised: March 23, 2015



©Intertek

SIP/CRP 60-01 (2 OF 2)

Division 7 - Thermal and Moisture Protection
07 40 00 Roofing and Siding Panels
07 41 43 Composite Roof Panels

Page 2 of 2

lamination procedure in accordance with the in-plant quality system documentation.

- D. **SPLINE (Not Shown):** Structural Insulated Panels are interconnected with surface splines or block splines.

Surface splines typically consist of 3 in. wide by 7/16 in. thick OSB. At each panel joint, one surface spline is inserted into each of two tight-fitting slots in the core. The slots in the core are located just inside the facing.

Block splines are manufactured in the same manner as the SIP except with an overall thickness that is 1 in. less than the overall thickness of the panel to be joined.

4. **GYPSUM BOARD:** Apply two (2) layers of 5/8 in. thick, Type X gypsum board to the interior side of the ceiling assembly (Item 1) oriented with the long dimension oriented perpendicular to the wood beams (Item 2). Secure the base layer using 1-1/4 in. long, bugle head self-drilling screws spaced nominally 8 in. on center (oc) around the perimeter and 12 in. oc in the field. Secure the second layer using 2 in. long bugle head self-drilling screws spaced nominally 8 in. oc around the perimeter and 12 in. oc in the field. Stagger joints of base layer and second layer.

- A. **JOINT TAPE AND COMPOUND – (Not Shown)** Apply a level 2 finish of vinyl or casein, dry or premixed joint compound applied in two coats to all exposed fastener heads and gypsum board joints. Embed minimum 2 in. wide paper, plastic, or fiberglass tape in first layer of compound over joints in gypsum board (Item 3).

5. **ROOF COVERING (Not Shown):** Use a Class A, B, or C hot mopped or cold applied roof covering, or use a ballasted, adhered or mechanically attached single ply roofing membrane.

Date Revised: August 7, 2013
Revised: March 23, 2015



©Intertek

SIP/CRP 60-02

Division 7 - Thermal and Moisture Protection
 07 40 00 Roofing and Siding Panels
 07 41 43 Composite Roof Panels

Page 1 of 2

Design Number: SIP/CRP 60-02
ROOF-CEILING SYSTEMS
Structural Insulated Panel Association (SIPA)
SIPA 4½ to 10½ in. Structural Insulated Panels
ASTM E 119 – 2012 Edition
CAN/ULC S 101 – 2007 Edition
Rating – 1 Hour
Restricted Superimposed Load: See Item 1

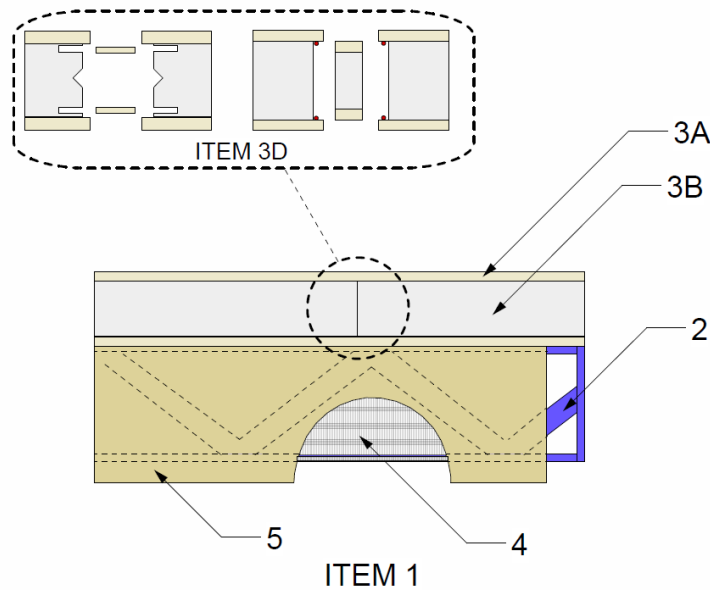

1. **CEILING ASSEMBLY:** Construct ceiling assembly using the elements described in Items 2 through 6 with a maximum restricted superimposed load of 57% of the allowable capacity of the panel.
2. **STEEL JOIST:** Use minimum Type 10K1 open-web steel joist constructed and spaced in accordance with manufacturer's design specifications and building code requirements.
3. **CERTIFIED COMPANIES:** Structural Insulated Panel Association (SIPA)

CERTIFIED PRODUCT: SIPA Structural Insulated Panels

ROOF PANELS: Install SIPA Structural Insulated Panels consisting of the following elements:

- A. **FACING:** Nominal 7/16 in. thick OSB skins factory bonded to interior and exterior sides of EPS foam core (Item 3A) conforming and identified as meeting DOC PS 2-04, Exposure 1, Rated Sheathing with a span index of 24/16 and/or CAN/CSA

Date Created: June 26, 2013
 Revised: March 23, 2015



©Intertek

SIP/CRP 60-02 (2 OF 2)

Division 7 - Thermal and Moisture Protection
07 40 00 Roofing and Siding Panels
07 41 43 Composite Roof Panels

Page 2 of 2

O325.0, Exterior Grade Sheathing with a span index of 1R24/2F16.

- B. CORE: Use ASTM C578 compliant and Listed Type I EPS (min. 0.9 pcf) with a flame spread rating not exceeding 75 and smoke-developed rating not exceeding 450 per ASTM E84 and/or CAN/ULC S701 compliant and Listed Type 1 EPS with a flame spread rating not exceeding 500 per CAN/ULC S102.2.
- C. ADHESIVE (Not Shown): Facing materials are adhered to the core material using a structural adhesive. The adhesive is applied during the lamination procedure in accordance with the in-plant quality system documentation.
- D. SPLINE: Structural Insulated Panels are interconnected with surface splines or block splines.

Surface splines typically consist of 3 in. wide by 7/16 in. thick OSB. At each panel joint, one surface spline is inserted into each of two tight-fitting slots in the core. The slots in the core are located just inside the facing.

Block splines are manufactured in the same manner as the SIP except with an overall thickness that is 1 in. less than the overall thickness of the panel to be joined.

4. METAL LATH: Install 3/8 in. expanded galvanized steel mesh weighing 3.4 lb/yd. to cover the exposed side of the steel joist (Item 2). Secure the lath using No. 20 SWG steel tie wire at the mid-point of alternate web members. Install the lath on the bottom of the roof panels (Item 3) using 1-1/2 in. deep x 15/16 in. wide C-pint staples spaced 7 in. on center (oc).
5. SPRAY APPLIED FIBER: Apply to the wetted surfaces of steel joist and panels, a minimum 11 pcf dry density Listed

spray applied fiber (CAFCO BLAZE-SHIELD Type DC-F) to the metal lath (Item 6). Apply at a minimum thickness of 2-1/4 in. to all mesh surfaces. Please reference the CAFCO BLAZE-SHIELD Type DC-F Code Evaluation Report for more details.

6. ROOF COVERING (Not Shown): Use a Class A, B, or C hot mopped or cold applied roof covering, or use a ballasted, adhered or mechanically attached single ply roofing membrane.

Date Created: June 26, 2013
Revised: March 23, 2015



©Intertek

SIP/CWP 60-01

Division 7 - Thermal and Moisture Protection
 07 42 00 Wall Panels
 07 42 43 Composite Wall Panels

Page 1 of 2

Design Number: SIP/CWP 60-01
EXTERIOR WALL SYSTEMS
Structural Insulated Panel Association (SIPA)
SIPA 4½, 6½ or 8¼ in. Structural Insulated Panels
ASTM E 119 – 2012 Edition
CAN/ULC S 101 – 2007 Edition
Rating – 1 Hour
Restricted Superimposed Load: See Item 1

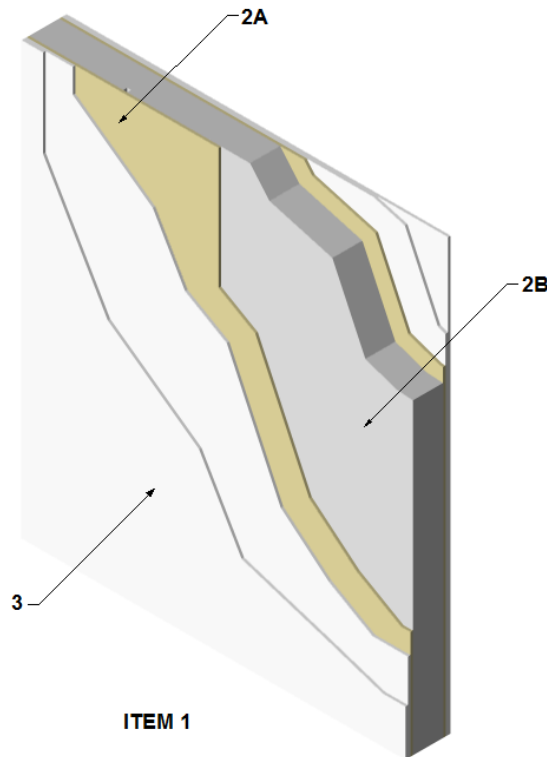

1. WALL ASSEMBLY: Construct a wall assembly using elements described in Items 2 through 4 up to a maximum of 9 feet in height with a maximum restricted superimposed load of 82% of the allowable capacity of the panel.
2. CERTIFIED COMPANIES: Structural Insulated Panel Association (SIPA)

CERTIFIED PRODUCT: SIPA Structural Insulated Panels

WALL PANELS: Install SIPA Structural Insulated Panels consisting of the following elements:

- A. FACING: Nominal 7/16 in. thick OSB skins factory bonded to interior and exterior sides of EPS foam core

Date Created: August 7, 2013
 Revised: March 23, 2015



©Intertek

SIP/CWP 60-01 (2 OF 2)

Division 7 - Thermal and Moisture Protection
 07 42 00 Wall Panels
 07 42 43 Composite Wall Panels

Page 2 of 2

- (Item 2B) conforming and identified as meeting DOC PS 2-04, Exposure 1, Rated Sheathing with a span index of 24/16 and/or CAN/CSA O325.0, Exterior Grade Sheathing with a span index of 1R24/2F16.
- B. CORE: Use ASTM C578 compliant and Listed Type I EPS (min. 0.9 pcf) with a flame spread rating not exceeding 75 and smoke-developed rating not exceeding 450 per ASTM E84 and/or CAN/ULC S701 compliant and Listed Type 1 EPS with a flame spread rating not exceeding 500 per CAN/ULC S102.2.
- C. ADHESIVE (Not Shown): Facing materials are adhered to the core material using a structural adhesive. The adhesive is applied during the lamination procedure in accordance with the in-plant quality system documentation.
- D. SPLINE (Not Shown): Structural Insulated Panels are interconnected with surface splines or block splines.
- Surface splines typically consist of 3 in. wide by 7/16 in. thick OSB. At each panel joint, one surface spline is inserted into each of two tight-fitting slots in the core. The slots in the core are located just inside the facing.
- Block splines are manufactured in the same manner as the SIP except with an overall thickness that is 1 in. less than the overall thickness of the panel to be joined.
3. GYPSUM BOARD: Apply two (2) layers of 5/8 in. thick, Type X gypsum board to the interior and exterior side of the wall assembly (Item 1) oriented vertically with the joints staggered 16 in. on center (oc). Secure the base layer using 1-5/8 in. long, bugle head self-drilling screws spaced nominally 12 in. oc around the perimeter and 24 in. oc in the field. Secure the second layer using 2 in. long bugle head self-drilling screws spaced nominally 12 in. oc around the perimeter and 24 in. oc in the field.
- A. JOINT TAPE AND COMPOUND – (Not Shown) Apply a level 2 finish of vinyl or casein, dry or premixed joint compound applied in two coats to all exposed fastener heads and gypsum board joints. Embed minimum 2 in. wide paper, plastic, or fiberglass tape in first layer of compound over joints in gypsum board (Item 3).
4. BEARING PLATES (Not Shown): Install nominal No. 2 lumber plates to the top and bottom of the wall panels (Item 2) in the pre-cut channel in the foam core covering the entire surface area and secure to the skins (Item 2A) using 8d common nails spaced nominal 6 in. oc. Prior to installing, apply a layer of acrylic latex caulk across the mating face with the EPS foam core (Item 2B).

Date Created: August 7, 2013
 Revised: March 23, 2015



©Intertek

SIP/CWP 60-02

Division 7 - Thermal and Moisture Protection
07 42 00 Wall Panels
07 42 43 Composite Wall Panels

Page 1 of 2

Design Number: SIP / CWP 60-02
EXTERIOR WALL SYSTEMS
Structural Insulated Panel Association (SIPA)
SIPA 6½ in. Structural Insulated Panels
ASTM E 119 – 2012 Edition
CAN/ULC S 101 – 2007 Edition
Rating – 1 Hour
Restricted Superimposed Load: See Item 1

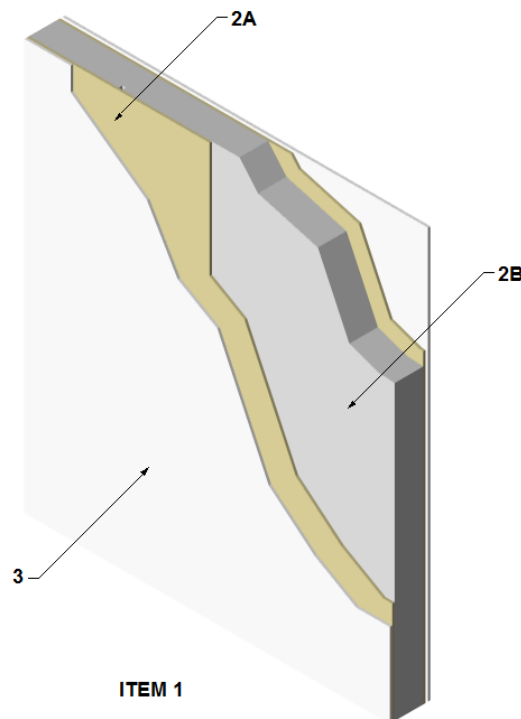

1. WALL ASSEMBLY: Construct a wall assembly using elements described in Items 2 through 4 up to a maximum of 10 feet in height with a maximum restricted superimposed load of 60% of the allowable capacity of the panel.
2. CERTIFIED COMPANIES: Structural Insulated Panel Association (SIPA)

CERTIFIED PRODUCT: SIPA Structural Insulated Panels

WALL PANELS: Install SIPA Structural Insulated Panels consisting of the following elements:

- A. FACING: Nominal 7/16 in. thick OSB skins factory bonded to interior and exterior sides of EPS foam core

Date Created: August 7, 2013
Revised: March 23, 2015

Intertek

©Intertek

SIP/CWP 60-02 (2 OF 2)

Division 7 - Thermal and Moisture Protection
07 42 00 Wall Panels
07 42 43 Composite Wall Panels

Page 2 of 2

- (Item 2B) conforming and identified as meeting DOC PS 2-04, Exposure 1, Rated Sheathing with a span index of 24/16 and/or CAN/CSA O325.0, Exterior Grade Sheathing with a span index of 1R24/2F16.
- B. CORE: Use ASTM C578 compliant and Listed Type I EPS (min. 0.9 pcf) with a flame spread rating not exceeding 75 and smoke-developed rating not exceeding 450 per ASTM E84 and/or CAN/ULC S701 compliant and Listed Type 1 EPS with a flame spread rating not exceeding 500 per CAN/ULC S102.2.
- C. ADHESIVE (Not Shown): Facing materials are adhered to the core material using a structural adhesive. The adhesive is applied during the lamination procedure in accordance with the in-plant quality system documentation.
- D. SPLINE (Not Shown): Structural Insulated Panels are interconnected with nominal 2 x 6 No. 2 lumber splines. At each panel joint, one 2 x 6 spline is installed in the precut channels in the foam core of the panel and secured to the skins (Item 2A) using 1 5/8 in. long ring shank steel nails spaced at a nominal 12 in. oc.
3. GYPSUM BOARD: Apply one (1) layer of 5/8 in. thick, Listed Type C gypsum board to the interior and exterior side of the wall assembly (Item 1) oriented vertically. Secure the gypsum board using 1-5/8 in. long, bugle head self-drilling screws spaced nominally 8 in. on center (oc) around the perimeter and 12 in. oc in the field.
- A. JOINT TAPE AND COMPOUND – (Not Shown) Apply a level 2 finish of vinyl or casein, dry or premixed joint compound applied in two coats to all exposed fastener heads and gypsum board joints. Embed minimum 2 in. wide paper, plastic, or fiberglass tape in first layer of compound over joints in gypsum board (Item 3).
4. BEARING PLATES: Panels are attached to nominal 2 x 6 No. 2 lumber top and bottom plates recessed into the precut channel in the foam core. Skins (Item 2A) are attached to the panels using 8d common nails spaced nominal 6 in. oc. Prior to installing, apply a layer of acrylic latex caulk across the mating face with the EPS foam core (Item 2B).

Date Created: August 7, 2013
Revised: March 23, 2015



©Intertek