

ICC-ES Evaluation Report

ESR-2182

Issued June 1, 2010

This report is subject to re-examination in one year.

www.icc-es.org | (800) 423-6587 | (562) 699-0543

A Subsidiary of the International Code Council®

DIVISION: 06—WOOD AND PLASTICS
Section: 06120—Structural Panels
REPORT HOLDER:
S PANEL HOLDINGS, LLC
 2420 HEYREND WAY
 IDAHO FALLS, IDAHO 83402
www.spansels.com
EVALUATION SUBJECT:
STRUCTURAL PANELS
1.0 EVALUATION SCOPE
Compliance with the following code:

 2006 *International Building Code*® (IBC)

Property evaluated:

Structural

2.0 USES

The S Panel Holdings, LLC, Structural Panels are used as structural roof and floor panels, and load-bearing and nonload-bearing wall panels, of Type V-B construction.

3.0 DESCRIPTION
3.1 General:

The panels are factory-assembled, laminated sandwich panels consisting of oriented strand board (OSB) facings with an expanded polystyrene (EPS) core. The panels are produced in total thicknesses of 6¹/₂ and 12³/₄ inches (165 and 324 mm), lengths up to 24 feet (7315 mm) and a width of 4 feet (1219 mm).

3.2 Wall Panels:

The 6¹/₂-inch-thick (165 mm) panels are used as wall panels. The core is recessed at the edges of the panels to allow for jobsite installation of OSB splines, and the core at the panel ends is recessed to receive solid sawn lumber wall plates.

3.3 Roof and Floor Panels:

The 12³/₄-inch-thick (324 mm) panels are used as roof and floor panels. The core of the panels is recessed along both panel edges to receive a lumber spline. The spline is factory-installed in one panel edge. The panel facings are attached to the spline with No. 16 gage by 1¹/₂-inch-long (38 mm) by ⁷/₁₆-inch-wide-crown (11.1 mm) staples spaced 3 inches (76 mm) on center. The core of the panels is recessed at the panel ends to receive rim joists. The

panels may be manufactured with one core butt splice that is orientated perpendicular to the panel span, located 12 inches (305 mm) from the support. The core butt splice location in the panel is identified by a paint marking on the panel.

3.4 Materials:

3.4.1 Panel Core: The panel core is EPS with a thickness of 5⁵/₈ or 11⁷/₈ inches (127 or 302 mm). The EPS specified in the approved quality control documentation complies with ASTM C 578 as Type I, has a nominal density of 1.0 pcf (16 kg/m³) and has a flame-spread index not exceeding 25 and a smoke-developed index not exceeding 450 when tested in accordance with ASTM E 84.

3.4.2 Facing: Facing material is ⁷/₁₆-inch-thick (11 mm), Exposure 1, Rated Sheathing, OSB sheathing complying with U.S. Department of Commerce PS-2-92 and requirements noted in the approved quality documentation.

3.4.3 Adhesive: The facing material is factory-bonded to the panel core material with a Type II, Class 2, adhesive specified in the approved quality control documentation.

3.4.4 Splines:

3.4.4.1 Lumber Splines: Lumber splines, factory-installed into one longitudinal edge of the roof and floor panels, are 1¹/₄-inch-thick (31.7 mm), 1.3E Timberstrand LSL rim board structural composite lumber manufactured by Weyerhaeuser and recognized in evaluation report [ESR-1387](#). The splines' depth is sized to match the panels' core thickness. Both panel facings are fastened to the splines with No. 16 gage, ⁷/₁₆-inch-crown-width (9.5 mm), 1¹/₂-inch-long (38 mm) staples spaced at 3 inches (76 mm) on center, with the staple crown oriented at an approximate 45-degree angle from the panel length.

3.4.4.2 OSB Splines: OSB splines, factory-installed into one longitudinal edge of the wall panels, are 4-inch-wide (102 mm) strips of the same OSB as described in Section 3.4.2. Both panel facings are fastened to the splines with No. 16 gage, ⁷/₁₆-inch-crown-width (9.5 mm), 1¹/₂-inch-long (38 mm) staples spaced at 3 inches (76 mm) on center, with the staple crown perpendicular to the panel edge.

4.0 DESIGN AND INSTALLATION
4.1 Design:

General: Combined axial and transverse loads on the wall panels must comply with the following equation:

$$\frac{\text{Actual Transverse Load [psf (kg/m}^2\text{)]}}{\text{Allowable Transverse Load [psf (kg/m}^2\text{)]}} + \frac{\text{Actual Axial Load [plf (kg/m)]}}{\text{Allowable Axial Load [plf (kg/m)]}} \leq 1.0$$

The allowable transverse loads for the panels are shown in Table 1. The use of the floor or roof panels to resist any other load conditions (such as a roof diaphragm resisting seismic or horizontal-wind loads) is outside the scope of this report. The allowable uniform axial compression loads on the 6¹/₂-inch-thick (165 mm) panels used as bearing walls with an 18-foot (5486 mm) maximum wall height is 2,028 plf (296 kN/m). The allowable racking shear loads for the 6¹/₂-inch-thick (165 mm) wall panels installed in accordance with this report with a maximum shearwall height-to-length ratio of 1-to-1 is 93 plf (1358 N/m).

4.2 Installation:

4.2.1 General: The panels must be installed in accordance with the manufacturer's published installation instructions and this evaluation report. A copy of the instructions must be available at all times on the jobsite during installation.

The longitudinal edges of the panels must be connected to each other with the factory-installed splines. The roof and floor panels are installed with the timber splines and the wall panels are installed with the OSB splines. Both panel facings must be fastened to the splines with No. 16 gage, 7/16-inch-crown (9.5 mm), 1¹/₂-inch-long (38 mm) staples spaced 3 inches (76 mm) on center, with the staple crown oriented at an approximate 45-degree angle from the panel length and with an edge distance of 3/16 inch (4.8 mm). Both panel facers must also be attached to solid sawn lumber framing at each side of wall openings, at wall corners and at each end of shearwalls with the same staples and staple spacing as noted for attachment at panel splines.

Top and bottom plates installed into the recessed core of the wall panels must be nominally 2-inch Douglas fir-larch solid sawn lumber, sized to match the panel's core thickness. Both the panel facings of the wall panels must be fastened to the top and bottom plates with the same fasteners, fastener orientation (crown width perpendicular to the panel end) and fastener spacing as described above for attachment of the splines to the panel facing. Figure 1 shows typical installation details. The wall panels must be installed in a manner such that the panel facers are in full contact and sufficiently supported by the underlying structure; and the loads applied at the top of the panel are uniform loads applied to both panel facers.

4.2.2 Wall Openings: Wall openings for doors and windows must be framed with conventional materials, and designed in accordance with the IBC, to the satisfaction of the code official.

4.2.3 Thermal Barrier:

4.2.3.1 Wall, Floor and Roof: A layer of 1/2-inch-thick (12.7 mm) gypsum wallboard, complying with ASTM C 36 or ASTM C 1396, must be installed on the interior surface of wall and roof panels and the bottom side of floor panels with occupied space below the floor panel. The gypsum wallboard must be fastened with No. 6 by 1¹/₄-inch-long (31.7 mm) Type W wallboard screws spaced at 16 inches (406 mm) on center at the perimeter of each gypsum wallboard and at 12 inches (305 mm) on center in rows spaced at 24 inches (610 mm) on center, in the field of the gypsum wallboard. The gypsum wallboard is also attached to the panels with OSI Formula No. 38 Drywall Adhesive, applied in 3/8-inch-diameter (9.5mm) beads spaced at 4¹/₂ inches (114mm) on center. Wallboard joints must be taped and filled with joint compound in accordance with GA-216 or ASTM C 840.

4.2.3.2 Floor Panels: An approved thermal barrier, such as 3/4-inch-thick (19.1 mm) plywood, must be installed on the top of floor panels to separate the panels from the interior of the building. The thermal barrier must be attached to the OSB facings of the sandwich panels in accordance with the code.

4.2.4 Exterior Wall Covering: The exterior face of the wall panels must be covered with an approved exterior wall covering, and a water-resistive barrier as required by IBC Section 1404.2. Where portland cement plaster is used, compliance with IBC Sections 2510 and 2512 is required. Flashing must be installed in accordance with the code.

4.2.5 Roof Covering: The roof panels must be covered with a roof covering complying with the code, including IBC Section 2603.6. Roofs with hot-asphalt or hot coal-tar pitch require mechanical attachment of a base ply prior to the application of the roof covering materials. Fasteners must have sufficient length to penetrate through the top panel skin. Underlayments and flashing must be installed in accordance with the code or a current evaluation report.

5.0 CONDITIONS OF USE

The panels described in this report comply with, or are suitable alternatives to what is specified in, the code indicated in Section 1.0 of this report, subject to the following conditions:

- 5.1** The panels must be fabricated, identified and erected in accordance with this report and the manufacturer's published installation instructions. If there is a conflict between the manufacturer's instructions and this report, this report governs.
- 5.2** Design loads to be resisted by the panels must be determined in accordance with the code, and must be less than the allowable panel loads noted in this report.
- 5.3** Construction documents, including engineering calculations and drawings providing floor plans, window opening details, door opening details, and connection details, must be submitted to the code official when application is made for a permit, to verify compliance with this report and the code. The design calculations and details must be prepared by a registered design professional where required by the statutes of the jurisdiction in which the project is to be constructed.
- 5.4** All roof-to-wall and wall-to-floor construction joint details must be designed such that gravity loads are applied to the wall panels as a uniform concentric axial load over the entire wall panel thickness.
- 5.5** When used as shear walls (racking shear), the panels are recognized for use in Seismic Design Categories A, B and C.
- 5.6** The panels are limited to use in structures of Type V-B construction.
- 5.7** The floor panels are limited to use in Group R occupancies.
- 5.8** The foam plastic core must be separated from the building interior by a thermal barrier installed in accordance with Section 4.2.3 of this report.
- 5.9** The panels must be installed a minimum of 6 inches (152 mm) above finish grade.

- 5.10 For use of the foam plastic in areas subject to damage from termites, installation must be in accordance with IBC Section 2603.8.
- 5.11 The panels and their attachments are subject to inspection by the code official prior to their being covered with an approved water-resistive barrier or roof covering.
- 5.12 For roof panel installations, justification must be submitted to the code official demonstrating that the panels with the roof covering comply as a Class A, B or C roof assembly as required by IBC Section 2603.6, with the classification also complying with the minimum classification requirements for the building.
- 5.13 The panels are fabricated in Idaho Falls, Idaho, under a quality control program with inspections by CI Professional Services. (AA-656).

6.0 EVIDENCE SUBMITTED

Data in accordance with the ICC-ES Acceptance Criteria for Sandwich Panels (AC04), dated October 2009.

7.0 IDENTIFICATION

Each sandwich panel must be labeled with the product name, name of the manufacturer (S Panel Holdings, LLC), the evaluation report number (ESR-2182), and the name of the inspection agency (CI Professional Services).

The LSL lumber splines must be labeled in accordance with evaluation report [ESR-1387](#).

TABLE 1—ALLOWABLE TRANSVERSE LOADS (psf)

PANEL SPAN (feet)	DEFLECTION LIMIT	6 ¹ / ₂ -INCH-THICK WALL PANELS: (WIND LOADS)	12 ³ / ₄ -INCH-THICK ROOF AND FLOOR PANELS ^{2,3,4}		
			Live Load	Snow Load	Wind Uplift Load
8	L/180	55	158	137	71
	L/240	52	158	103	71
	L/360	35	109	69	71
10	L/180	44	125	108	58
	L/240	38	125	81	58
	L/360	26	83	54	58
12	L/180	37	102	88	50
	L/240	29	102	66	50
	L/360	19	65	44	50
14	L/180	30	86	74	43
	L/240	23	83	55	43
	L/360	15	52	37	43
16	L/180	24	74	63	39
	L/240	18	68	47	39
	L/360	12	42	32	39
18	L/180	19	65	55	35
	L/240	14	56	41	35
	L/360	10	34	27	35
19	L/180	17	—	—	—
	L/240	13	—	—	—
	L/360	9	—	—	—
20	L/180	—	57	48	32
	L/240	—	47	36	32
	L/360	—	28	24	32
22	L/180	—	51	42	30
	L/240	—	39	31	30
	L/360	—	23	21	30
23	L/180	—	49	40	29
	L/240	—	36	30	29
	L/360	—	21	20	29

For SI: 1 inch = 25.4 mm, 1 psf = 47.9 Pa.

¹The maximum spacing of the panel splines is 4 feet.

²The allowable transverse load is the total applied load; the self-weight of the panel need not be included within the allowable loads shown.

³Panels with a butt splice of the panel core shall be installed with the core butt splice located a minimum of 12 inches from the panel support.

⁴The minimum bearing width for roof and floor panels provided by the panel supports (such as walls and beams) is 1 inch. For wind uplift loads, the roof panel must be restrained by fasteners with 2-inch-diameter washer spaced at a maximum of 12 inches on center.

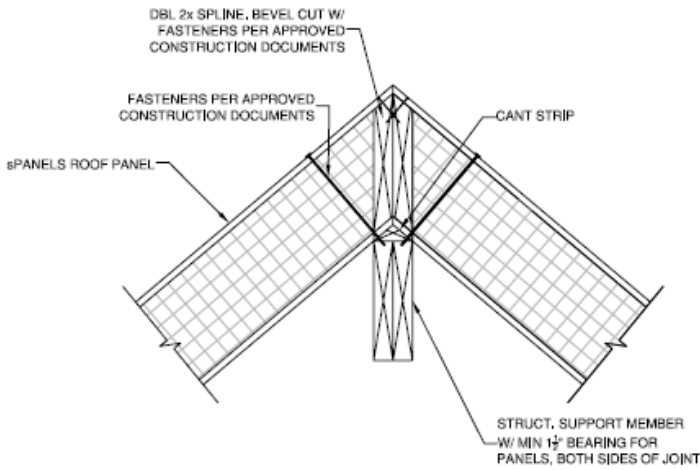

ROOF PANEL ASSEMBLY

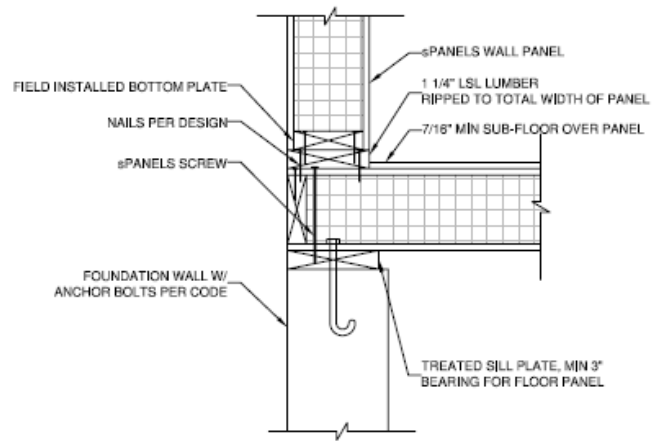

PANEL ASSEMBLY

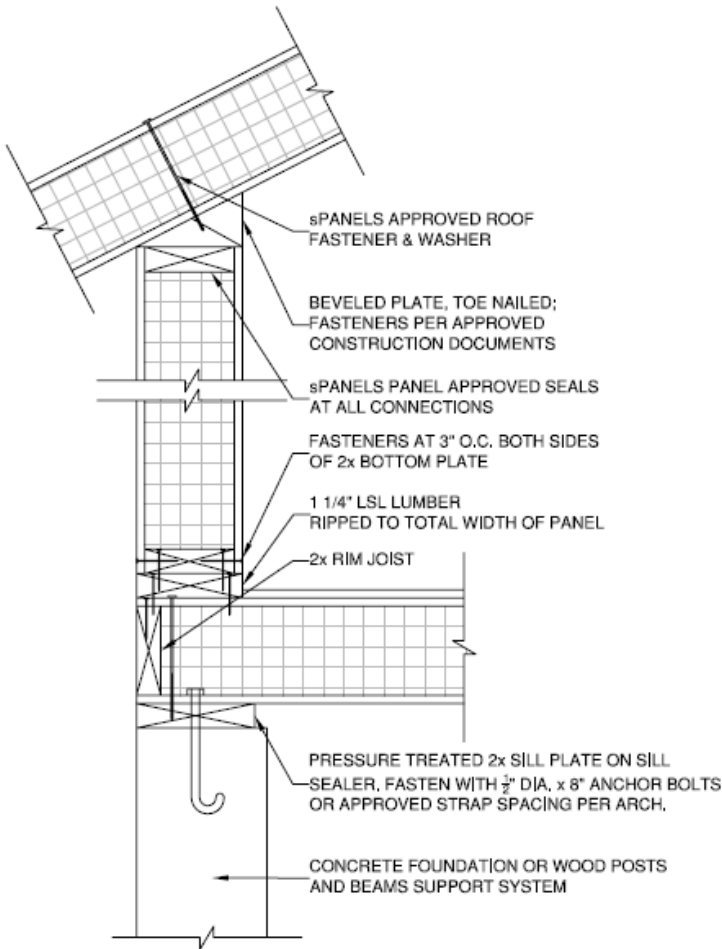

ROOF & WALL ASSEMBLY

FIGURE 1—TYPICAL INSTALLATION DETAILS